

Ion sensitive probe measurement in the linear plasma device PSI-2

N. Ezumi^{a,*}, Zh. Kiss'ovski^b, W. Bohmeyer^c, G. Fussmann^c

^a Nagano National College of Technology, 716 Tokuma, Nagano 381-8550, Japan

^b Faculty of Physics, Sofia University, Sofia 1164, Bulgaria

^c Max-Planck-Institut für Plasmaphysik, Bereich Plasmadiagnostik, Brook-Taylor-Str. 6, 12489 Berlin, Germany

Abstract

The suitability of an ion sensitive probe (ISP) with respect to ion temperature (T_i) measurements has been tested in the linear plasma generator in PSI-2. Current–voltage (I – V) characteristics were recorded as a function of two key parameters: shielding height (h) and potential differences between inner and outer electrodes (V_B). It could be experimentally confirmed that the current within the electron saturation region is reduced with increasing h . Furthermore, the I – V characteristics change drastically when V_B is varied. Radial profiles of the plasma parameters including plasma and floating potentials could be taken. Whereas the T_i values determined by ISP in the plasma core region agree fairly with those obtained by using a local optical probe, severe interpretation difficulties occurred for the outer regions.

© 2004 Elsevier B.V. All rights reserved.

PACS: 52.40.Hf; 52.70.–m; 52.70.Ds; 52.70.Nc

Keywords: Divertor plasma; Edge plasma; Electric field; Probes; Sheaths

1. Introduction

The importance of the edge and divertor plasma with regard to improved confinement and plasma performance in magnetic fusion devices is well known. The control of the ion temperature in these regions is one of the keys for achieving such improvements. There are several methods available for measuring T_i in such boundary regions. The conventional optical method, based on Doppler broadening, suffers from the difficulty to yield local values and T_i profiles because the primary

data is integrated over the line of sight. A alternative diagnostic system which allows high spatial resolution in the cooler plasma edge regions is therefore very much desired. In this respect an ion sensitive probe (ISP) [1] could be a very useful supplement. Used in magnetized plasmas, an ISP allows simultaneous measurements of electron and ion temperature, electron density (n_e) as well as local plasma (space) (V_s) and floating potential (V_f). The large difference in Larmor radii is utilized to separate ions and electrons. A typical ISP consists of two electrodes, an ion collector (referred to as ‘P’ or ‘inner electrode’) and an electron guard electrode (referred to as ‘G’ or ‘outer electrode’). The inner P-electrode is mounted coaxially inside of the G-electrode. Both elec-

* Corresponding author.

E-mail address: ezumi@ec.nagano-nct.ac.jp (N. Ezumi).

trodes are electrically isolated from ground potential. Because of geometrical conditions, the inner electrode is expected to collect ions only – even in cases when the biasing voltages applied to both electrodes is positive with respect to plasma potential. The outer electrode works as a fence to prevent electrons from reaching the inner ion collector. T_i can be determined by analyzing of the current–voltage ($I-V$) characteristic of the inner electrode similarly as T_e is obtained from the $I-V$ characteristic of the outer one. Hitherto, ion sensitive probes have been tested in the JFT-2M edge plasma [2], the LHD divertor [3], and the linear divertor plasma simulator NAGDIS-II [4]. Quite a few uncertainties with respect to the interpretation of the observed $I-V$ characteristics emerged from these investigations. It is the aim of this study to present new experimental material which may help to clarify the underlying physics.

2. Experimental setup

2.1. Linear plasma generator PSI-2

T_i measurements using an ISP and, alternatively, applying an optical method have been performed in the linear plasma generator PSI-2 at IPP-Berlin [5]. This device is equipped with six magnetic coils generating a magnetic field of about 0.1 T. The anode and the vacuum vessel are electrically connected to the ground. Argon as primary gas was introduced into the discharge region between cathode and anode to generate a steady

state plasma. A discharge current of 150 A was chosen and the neutral pressure in the target chamber region, where the actual measurements were performed (1.65 m behind the cathode), was measured to 0.018 Pa. The cylindrical plasma column of about 2 m length and 8 cm diameter is terminated by a neutralizer plate on floating potential.

2.2. Ion sensitive probe with variable shielding height

Fig. 1 shows the schematics of ISP used in the PSI-2 device. It consists of two cylindrical electrodes, the ion collector (P) and the electron guard electrode (G). The P and G-electrodes are made from W and Mo, respectively. The distance between the top surface of the ion collector and the upper end of the G-electrode is defined as the shielding height h . For $h = 0$ the tips of both electrodes coincide. The optimum value of h for the experimental condition in PSI-2 was estimated at 0.7–0.8 mm invoking Katsumata’s theory [1], where n_e , T_e and the magnetic field (B) were assumed to $5 \times 10^{18} \text{ m}^{-3}$, 5 eV and 0.1 T, respectively. In the experiments h could be varied by means of a linear feed-through to a precision of 0.05 mm. The P- and G- electrodes are connected to electrical feed-throughs assembled within the manipulator probe drive system as shown in Fig. 1. The whole probe can be moved perpendicular to the field lines thus allowing radial scans over the plasma cross-section.

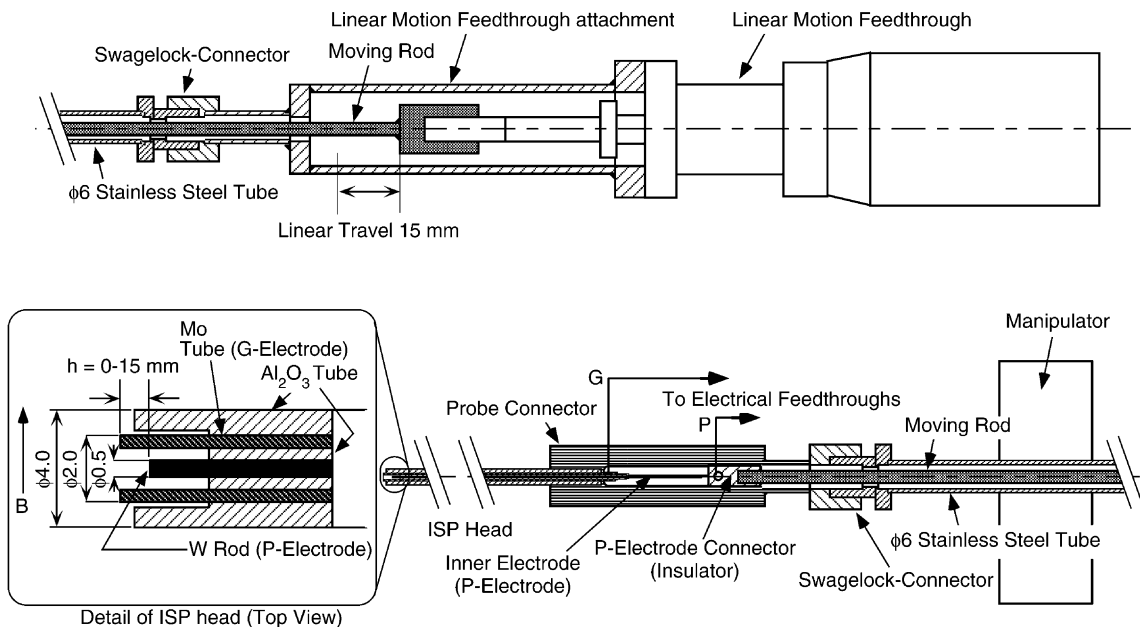

Fig. 1. Structure of the ISP head and schema of the ISP drive system used for measurement in PSI-2.

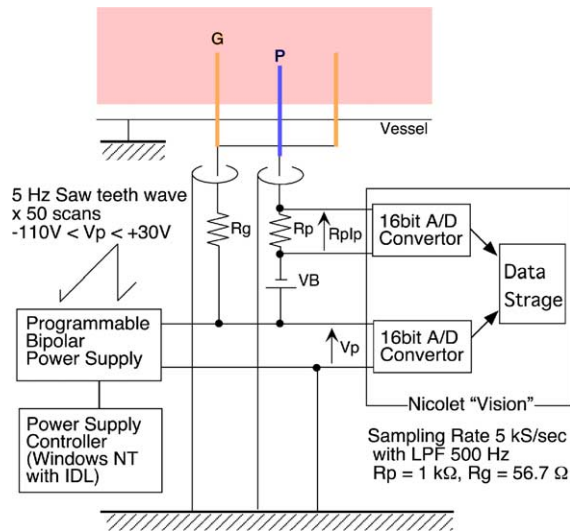

Fig. 2. ISP electric circuit.

2.3. Electric circuit for ISP measurements

Fig. 2 shows the diagram of the electric circuit. In order to obtain $I-V$ characteristics suitable for T_i evaluation it is important to fix the potential difference between the electrodes when changing the bias voltage. An additional battery, providing the voltage V_B , is used for this purpose. The probe currents of the P- and G-electrodes are obtained from the voltage measured across the resistors $R_p = 1 \text{ k}\Omega$ and $R_g = 56.7 \Omega$, respectively. R_g is only needed to measure T_e , space potential (V_s) and n_e . With respect to an $I-V$ characteristic of the P-electrode the resistor R_g works as a shunt, i.e. essentially a shortage. Characteristics are taken by applying a saw-tooth wave to both probe electrodes where the range of the scanning voltage is between -110 and $+30 \text{ V}$. A sweep frequency of 5 Hz was used in most experiments. Data acquisition of voltage (V_p) and probe current from the P-electrode (I_p) is accomplished by means of a 16 bits digitizer using a sampling rate of 5 k samples/s and a 500 Hz low pass filter.

3. Experimental results and discussion

3.1. Variation of the shielding height

Fig. 3 shows the influence of the shielding height parameter h on the $I-V$ characteristic. Here the probe was located in the center region of plasma column. In the case of $h = 0$, the $I-V$ curve shows a large negative saturation current in the positive voltage region. This curve is similar to common single probe characteristics. With increasing h the current within this electron satura-

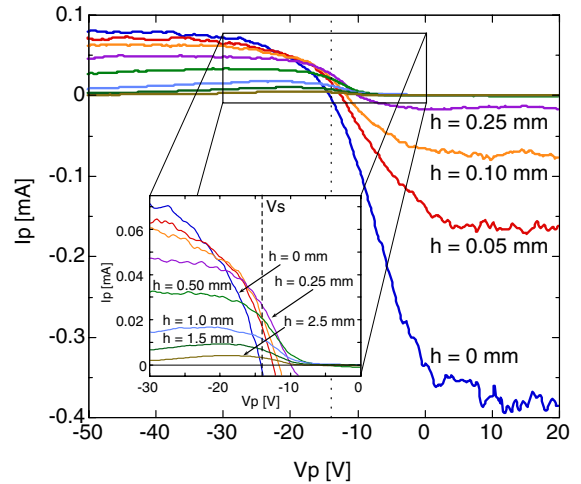

Fig. 3. $I-V$ characteristics of the inner P-electrode with respect to variation of the shielding height parameter h ($r = 0.5 \text{ cm}$, $V_B = -3 \text{ V}$).

tion region is seen to decrease drastically. For $h \geq 0.5 \text{ mm}$ and positive voltage the currents are almost zero. These results indicate that the separation of ions and electrons is successfully accomplished by the ISP. For the experimental conditions the Larmor radius of the electrons is about 0.1 mm , i.e. much larger than the Debye length which is only about 0.02 mm . For these values, the critical shielding height is estimated from ref. [1] to about 1 mm . The experimental results are thus in good agreement with the theoretical prediction.

3.2. Variation of the potential difference between the electrodes

Fig. 4 shows the variation of $I-V$ curves near the centre of plasma column ($r = 0.5 \text{ cm}$) for several settings of V_B . The minus sign of V_B indicates that the ion collecting P-electrode is more negative than the guarding G-electrode. As is to be seen from the figure the $I-V$ characteristics change drastically with V_B . In the cases $V_B = 0$ and $+1 \text{ V}$ pronounced negative (electron) currents are observed. On the other hand, for $V_B < 0$ these negative currents are reduced and finally disappear completely. If the electrical potential of the P-electrode is positive with respect to the G-electrode, electrons are collected by the P-electrode as seen in the cases $V_B = 0$ or $+1 \text{ V}$. These – initially unexpected – currents can be explained by the $E \times B$ drifts imposed onto the particles by the strongly inhomogeneous E-field in the close vicinity of the probe [6]. In order to suppress such undesired electron currents to the P-electrode it should be always negatively biased with respect to the G-electrode. As a first measure, this can be accomplished by the choice of the materials. Looking for the work functions of

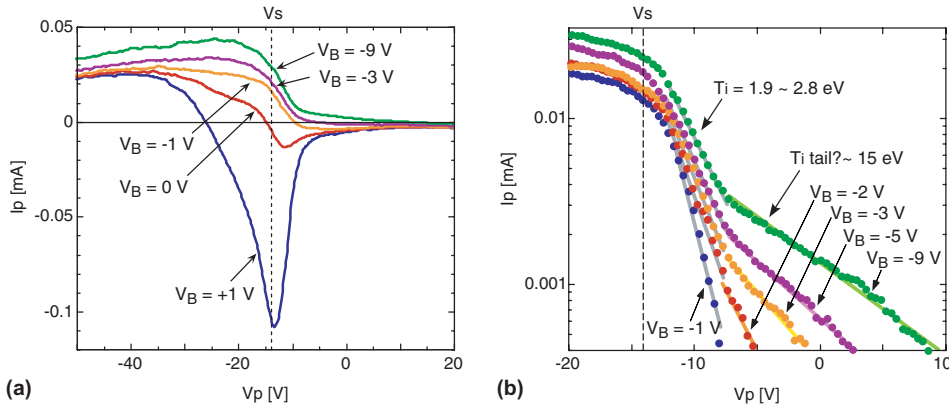

Fig. 4. Characteristics like in Fig. 3 but with respect to variation of the potential difference V_B . (a) Currents to linear scale ($r = 0.5$ cm, $h = 0.46$ mm). (b) Currents to log scale ($r = 0.5$ cm and $h = 0.76$ mm).

tungsten (4.5 eV) and molybdenum (4.2 eV). A voltage difference of $\phi_P - \phi_G = -0.3$ V can be expected for clean surfaces by choosing W for the P- and Mo for the G-electrode. One reason to apply an additional negative voltage (V_B) is to compensate for changes of the work functions due to changing surface condition (deposition of impurities).

On the other hand, for too large negative V_B high energy tails in the ion distribution function become obvious in the log-linear plot presented in Fig. 4(b). At low energies, however, the slopes are less sensitive with regard to variation of the V_B parameter and allow the determination of the ion temperature within a certain range of uncertainty (here $T_i = 1.9$ to 2.8 eV). In order to reduce this uncertainty a negative V_B as small as possible (but satisfying $I_P > 0$) are to be applied.

3.3. T_i -measurements

Radial profile measurements of T_i , T_e , V_s as well as floating potential (V_f) and density (n_e) were performed in the target chamber at a neutral gas pressure of $P_n \approx 0.018$ Pa. The results are shown in Fig. 5. T_i was obtained from the $I-V$ characteristics of the P-electrode whereas T_e , V_s , V_f and n_e were evaluated from the characteristics of the G-electrode. While the plasma potential (V_s) is almost constant in the central region, it is seen to rise in the outer region $r > 2$ cm. The profiles of n_e and T_e are hollow (due to the design of the cathode which is hollow too) and peak around $r = 2$ cm and 2.5 cm, respectively. Unfortunately, T_i could only safely be determined for the center region of plasma. The absolute values of T_i evaluated from these ISP measurements are substantially lower than the those obtained by the high resolution emission spectroscopy ($T_i \approx 5$ eV, at $r = 1.1$ – 2.1 cm). It cannot be excluded, however, that the presence of high temperature ions in the edge region of the plasma had some influence on these optical T_i measurements for the reasons discussed in the introduction. That the optically determined values are actually too high is also corroborated by more recent measurements using a new optical probe in PSI-2 that allows space resolved measurements [7]. Flat profiles with $T_i \approx 2.5$ eV were found by using this probe which, at least for the core region, is consistent with the ISP results.

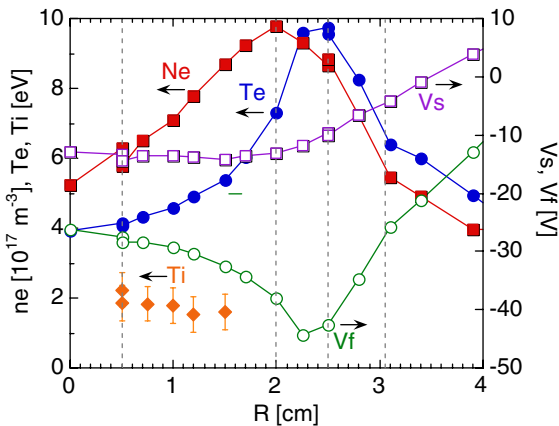

Fig. 5. Radial profiles of T_i , T_e , V_s , V_f and n_e . T_i was measured using the parameter settings: $h = 0.76$ mm, $V_B = -1$ or -2 V.

3.4. Anomalous $I-V$ characteristics in the outer plasma regions

As shown in Fig. 5, T_i was evaluated only in the center region of the plasma column. In fact, anomalous $I-V$ characteristics in the outer region, as shown in Fig. 6, do not permit a reasonable evaluation. The $I-V$ curve taken at the plasma core region ($r = 0.5$ cm) shows $I_p \approx 0$ for

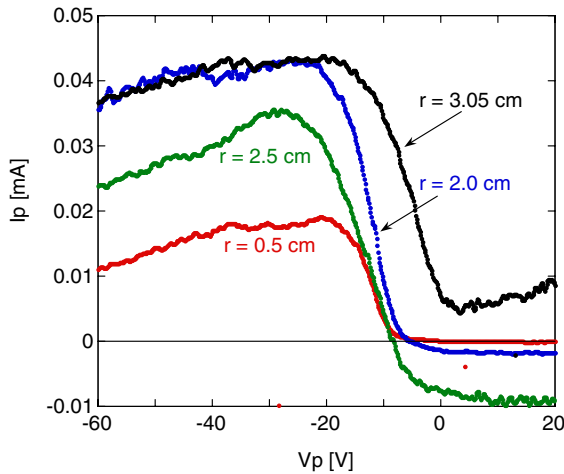

Fig. 6. I - V characteristic of the P-electrode at various radial positions. Parameter settings for each position were as follows: (i) $r = 0.5$ cm, $h = 0.76$ mm, $V_B = -1$ V, (ii) $r = 2.0$ cm, $h = 0.76$ mm, $V_B = -1.5$ V, (iii) $r = 2.5$ cm, $h = 1$ mm, $V_B = -2$ V, (iv) $r = 3.0$ cm, $h = 0.76$ mm, $V_B = -2$ V.

positive probe voltages. In this case T_i can be determined from the logarithmic slope of characteristics. However, unsuitable characteristics are observed for $r \geq 2$ cm (i.e. approximately beyond the position where T_e reaches maximum). Although applying the optimal settings for h and V_B , negative currents for positive probe voltages are observed. In contrast, large positive currents are found even for large positive probe voltage in the plasma edge region ($r = 3.0$ cm). Surprisingly, the critical settings of the shielding parameters ($h_c = 10\lambda_d + 10\rho_{ce}$) [1] for the two positions $r = 3$ cm and $r = 2$ cm do not differ. The most different parameters at the two positions are density and plasma potential (see Fig. 5). In particular n_e is about a factor of 2 larger for the lower position. On the other hand, the density is low also in the core region where no anomalies in I - V characteristics are observed. With respect to V_s , its radial profile is almost flat in the center region $r \leq 2$ cm but substantial gradients occur for larger radii. This may indicate that the anomalous characteristics are related to the radial electric field. There are, however, other mechanisms conceivable to explain such anomalous I - V behavior, as for instance, an influence from the poloidal electric field or ion drift waves which have been observed to be present in this region [8]; secondary and thermal electron emission, or

high energetic electron tails may also interfere with the ISP measurements.

4. Conclusions

An ion sensitive probe has been successfully applied in PSI-2 to determine temperatures, density and potentials as a function of radius. However, I - V characteristics suitable for evaluating T_i were found in the plasma center region only. The evaluated ion temperatures show a weak dependence on shielding height and potential differences between the two electrodes. In contrast, anomalous probe signals, inappropriate to determine T_i , were recorded in the plasma boundary region where relatively large radial electric fields as well as ion drift waves occur.

Acknowledgments

We specially thank Professor Takamura and the staff of his lab from Nagoya University for helpful discussion. We also thank Dr M. Laux, B. Koch, T. Lunt and the PSI-2 group at IPP-Berlin for useful discussions. This work is performed with the support and under the auspices of the LHD International Mutual Experiments Program.

References

- [1] I. Katsumata, Contribution Plasma Phys. 36S (1996) 73.
- [2] K. Uehara, A. Tsushima, H. Amemiya, JFT-2M Group, J. Phys. Soc. Jpn. 66 (1997) 921.
- [3] N. Ezumi, S. Masuzaki, N. Ohno, Y. Uesugi, S. Takamura, LHD Experimental Group, J. Nucl. Mater. 313–316 (2003) 696.
- [4] N. Ezumi et al., in: Proceedings of 15th Annual conference of the Japan Society of Plasma Science and Nuclear Fusion Research, 1998, p. 173 (in Japanese).
- [5] S. Klose, W. Bohmeyer, M. Laux, H. Meyer, G. Fussmann, the PSI-team, Contribution Plasma Phys. 41 (5) (2001) 467.
- [6] N. Ezumi, Contribution Plasma Phys. 41 (5) (2001) 488.
- [7] Zh. Kiss'ovski, W. Bohmeyer, G. Fussman, Contribution Plasma Phys. 43 (7) (2003) 456.
- [8] S. Klose, W. Bohmeyer, M. Laux, H. Meyer, G. Fussmann, PSI-team, Contribution Plasma Phys. 41 (5) (2001) 467.